

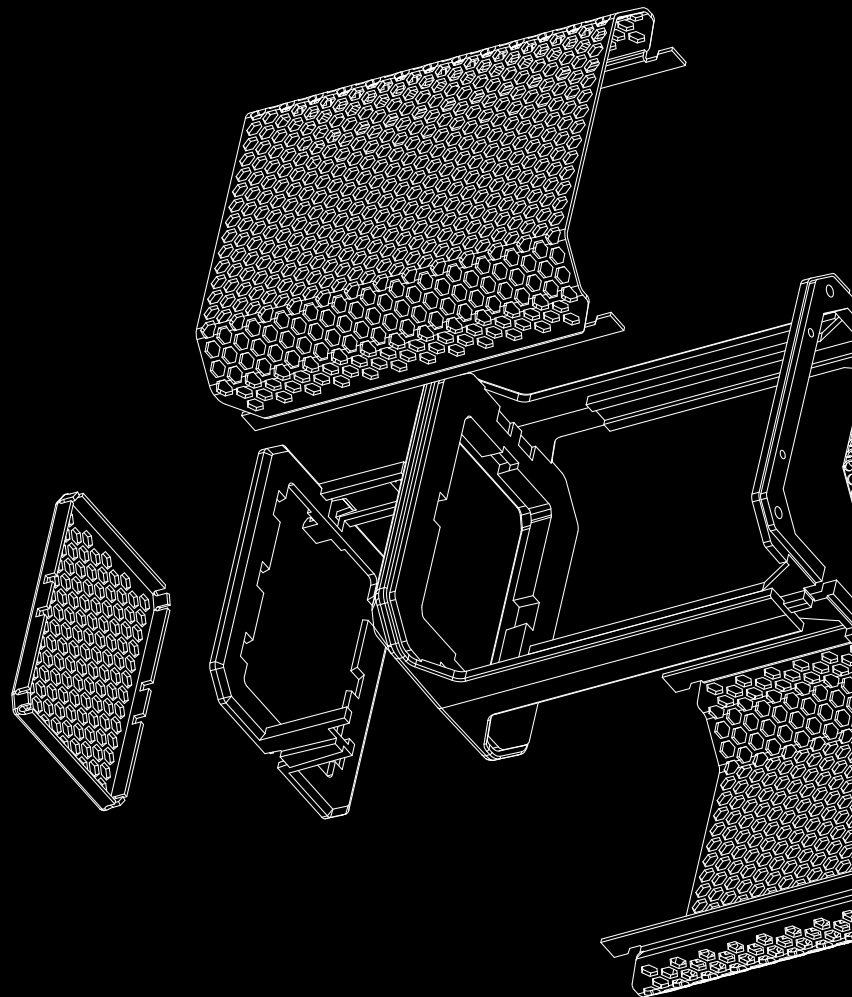

PRODUCT CATALOG

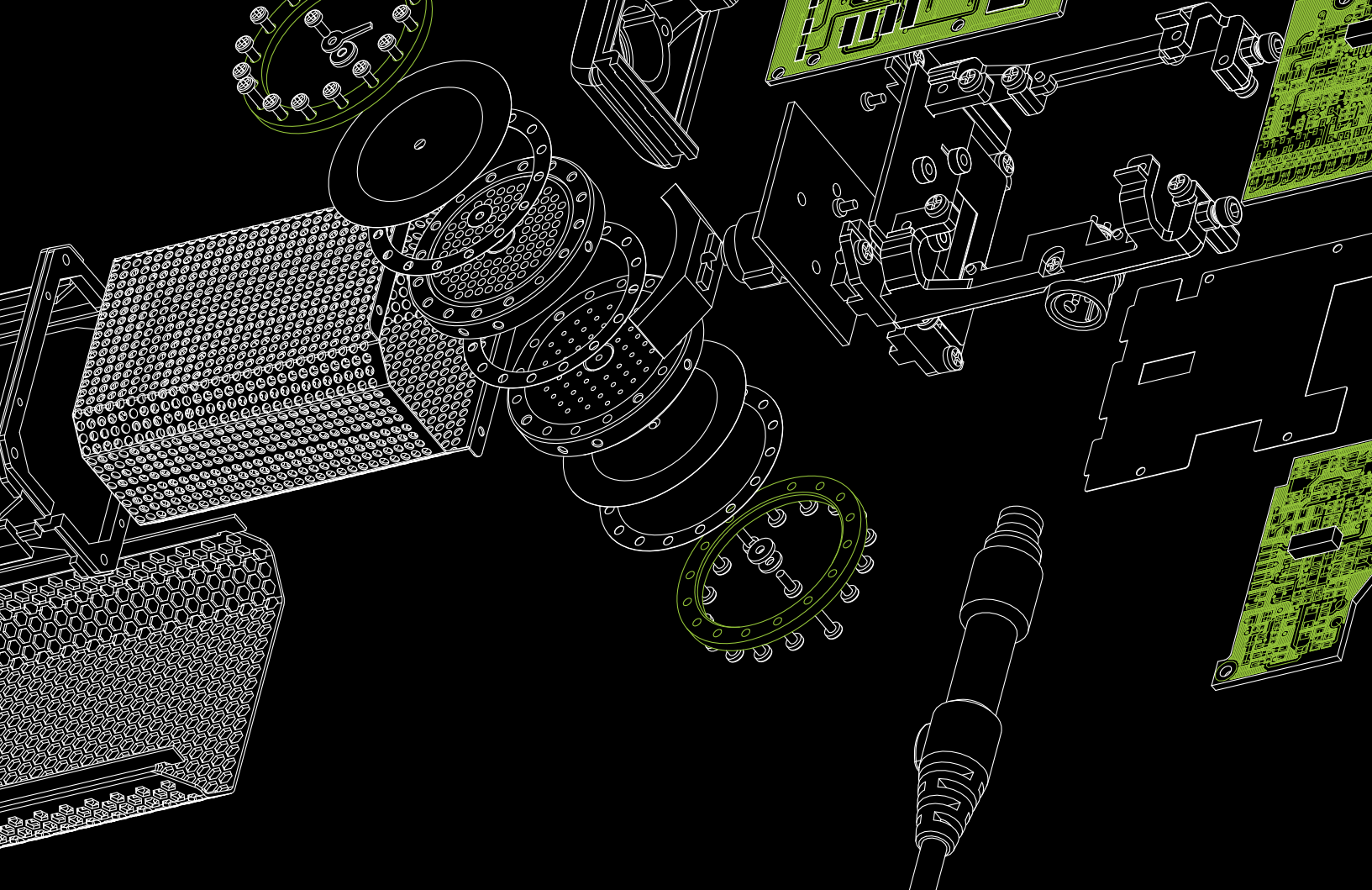

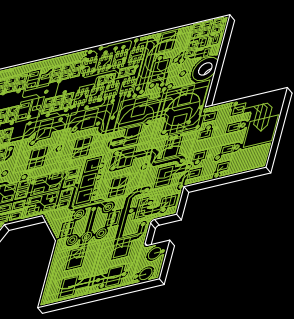

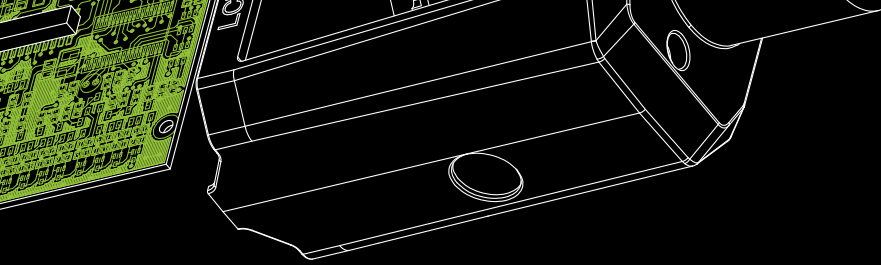

INTRO

LEWITT pursues new, progressive microphone designs driven by the urge for innovation. An integral part of the design process is to involve producers, sound engineers, and musicians with their practical approach. As a result, the microphones have innovative features that further improve their performance. High-end circuit designs and precision-engineered capsules deliver authentic and vibrant sound. This allows every studio and stage performance to be captured in its genuine liveliness without technical limitations. In this respect, it is no surprise that LEWITT has established itself as the go-to microphone brand for an ever-growing number of professionals around the globe.



MAKE YOURSELF HEARD.
UNALTERED. AUTHENTIC. MEMORABLE.

CONTENTS

Studio.....	6-23
Live.....	24-31
Drums.....	32-37
Broadcasting.....	38-41
Digital.....	42-45
Conference.....	46-51
Endorser.....	53





METROPOLIS STUDIOS, LONDON
ADELE, AMY WINEHOUSE, MICHAEL JACKSON, RIHANNA, ...



STUDIO

LEWITT's engineers are continually working to push the boundaries of current microphone technology. This approach is effective with all LEWITT microphones. The main goal is to provide all audio professionals with tools that not only make their work easier, but also fundamentally improve the quality of their work. With this approach, LEWITT is able to establish itself as an exceedingly popular microphone brand in a growing number of studios.





LCT 240 PRO

CASEY ABRAMS, POSTMODERN JUKEBOX





LCT 240 PRO

Condenser

The perfect all-rounder for your project studio. Clear and modern sound in a compact housing.

Included: Mic mount, Windscreen, Mic bag



LCT 440 PURE

Condenser, Large Diaphragm

Compact 1" studio microphone with high-end components. Pure sound for every application.

Included: Shock mount, Magnetic pop filter, Windscreen, Mic bag

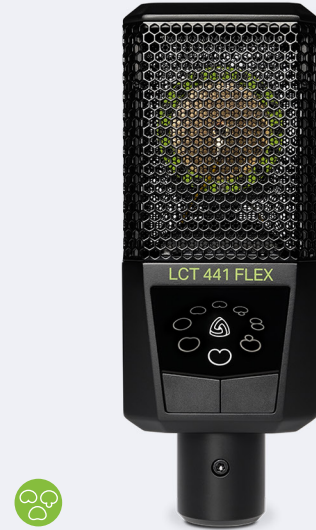

LCT 441 FLEX

Condenser, Large Diaphragm

Features eight different polar including three reverse patterns for full flexibility.

Included: Shock mount, Magnetic pop filter, Windscreen, Mic bag

Every single microphone that is using the Perfect Match technology undergoes a series of measurements followed by adjustment of the polarization voltage to achieve the exact same sensitivity at 1 kHz within a model line.

Models:

LCT 540 S

LCT 640 TS





PERFECT MATCH TECHNOLOGY
THE FUTURE OF STEREO RECORDING

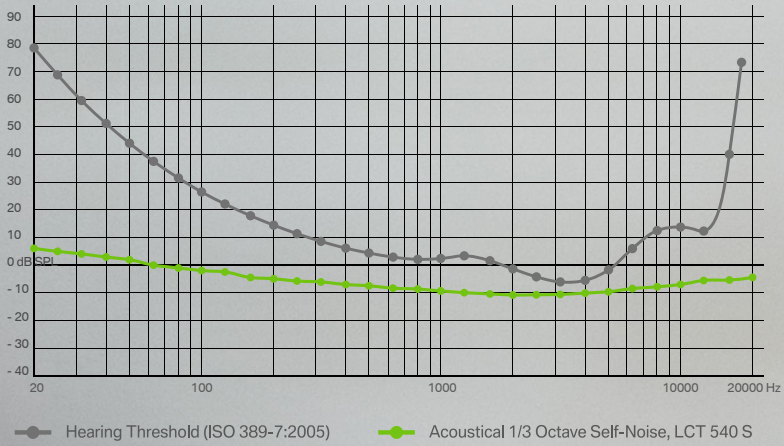

LCT 540 S
BETTER THAN HUMAN HEARING

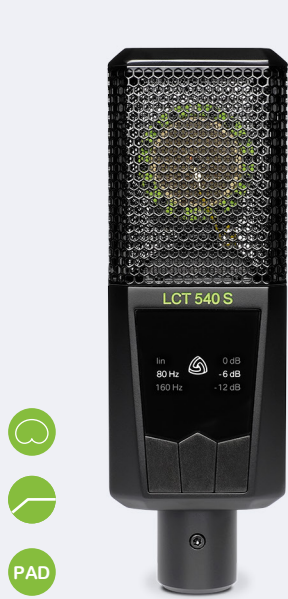

// ULTRA-DETAILED SOUND IMAGES
// BETTER THAN HUMAN HEARING
// OUTSTANDING VOCAL RECORDINGS
// SUITABLE FOR ANY APPLICATION
// PERFECT MATCH TECHNOLOGY

LCT 540 S

**Condenser, Large Diaphragm,
Perfect Match Technology**

Cutting-edge microphone for ultra-detailed sound images with high-end self-noise architecture.

Included: Shock mount, Magnetic pop filter, Windscreen, Mic bag, Transport case

Details:

The engineering of this particular piece of cutting-edge audio technology asked for a forward-thinking approach towards capsule and circuit design. Get involved with tone and sound in ways unheard and bring your recordings to perfection by capturing all the fine-grained characteristics that constitute each moment of your performance. To guarantee its ultra-resolution sound and first-class sonic imaging, every 3 μm gold-sputtered, 1" Mylar diaphragm underlies the strictest quality controls.



LCT 640 TS

PRESERVE YOUR CREATIVE FREEDOM

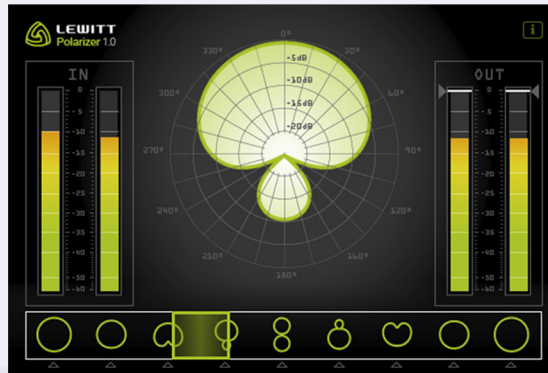
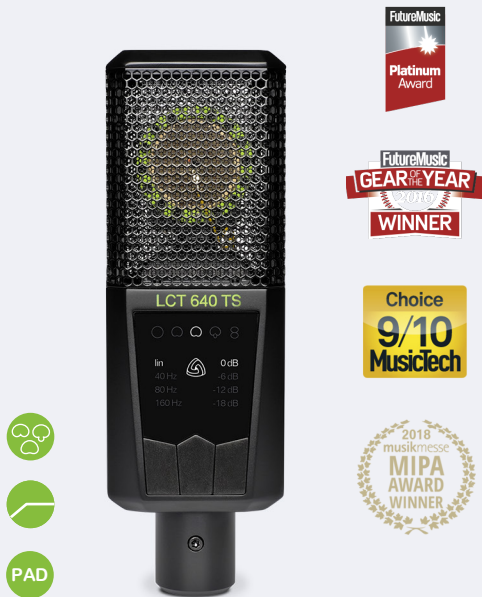

LCT 640 TS

**Condenser, Dual Output Mode,
Perfect Match Technology**

1" multi-pattern microphone with unique recording functionalities. **Included:** Shock mount, Magnetic pop filter, Windscreen, TS adapter cable, Mic bag, Transport case

Details:

The LCT 640 TS will revolutionize the way we think about the recording process. Set to **Dual Output Mode**, two independent circuitries provide the signal of the mic's front and back diaphragm separately. Already recorded material can be changed dynamically by adjusting the polar pattern - room sound can be added or decreased, even a turn by 180° is possible. You can either do that manually on a mixing console or use the **POLARIZER** plugin to tweak the material with incredible ease of use. Available for Mac and Windows (VST, AU, AAX).



middle
2

bass

// OPEN FRONT FOR SUPER-CLOSE POSITIONING

// MINIMIZES STRUCTURE-BORNE NOISE

// FAST AND EASY SETUP

// SECURE FASTENING

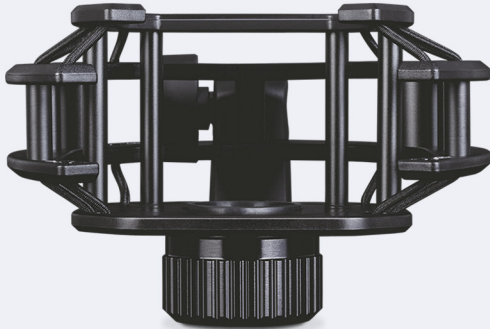

LCT SHOCK MOUNT

LCT 40 SH: Compatible with LCT 240 PRO, LCT 440 PURE, LCT 441 FLEX.

LCT 40 SH WH: White version of the LCT 40 SH.

LCT 40 SHX: Compatible with LCT 540 S, LCT 640 TS.

LCT 40 SHXX: Compatible with LCT 840, LCT 940.

LCT 40 SHS: Compatible with LCT 140, LCT 340.





- // EFFECTIVELY REDUCES POPS AND HISSES**
- // DOES NOT COVER THE VOCAL ARTIST'S FACE**
- // HOLDS IN PLACE MAGNETICALLY**
- // INTEGRATES WITH THE DESIGN OF THE SHOCK MOUNT**



MAGNETIC POP FILTER

LCT 50 PSX: Compatible with LCT 40 SHx, LCT 40 SHW, LCT 40 SH.

Atlantic Records NY

Artists:

Ed Sheeran

Bruno Mars

Coldplay

Aretha Franklin

Led Zeppelin

Genesis

Cher

... and many more.





**RON ROBINSON, ATLANTIC RECORDS
STUDIO DIRECTOR & PRODUCER**



LCT 840

Condenser, Large Diaphragm

Super-low self-noise multi-pattern tube microphone with a spectacular view.

Included: Shock mount, Windscreen, 11-pin audio cable, Power supply and remote control, Transport case

Details:

The LCT 840, equipped with a precision-engineered 1" capsule, stands for exceptionally warm and classic tube sound. It offers highly nuanced and authentic sound reproduction in the studio and even onstage. Five switchable polar patterns plus three low-cut and pre-attenuation settings make the LCT 840 a highly versatile tool. The illumination of the user interface makes possible a quick and accurate setup of pattern, pre-attenuation and low-cut - so even in total darkness, it is easy to check or change the settings.

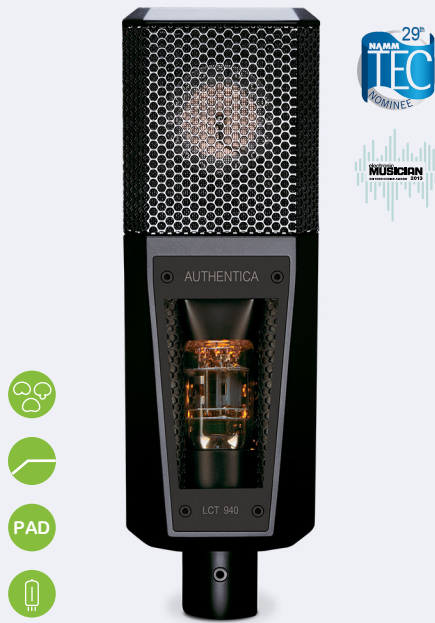

LCT 940

Condenser, Tube/FET Combination

Tube and FET microphone in one housing. Mix the two sound characteristics at any ratio and find your individual sweet spot.

Included: Shock mount, Windscreen, 11-pin audio cable, Power supply and remote control, Transport case

Details:

The LCT 940 combines a premium large-diaphragm FET condenser microphone and a top-notch tube microphone in a single housing. Choose between the two main settings of TUBE and FET or find your sweet spot in between - they are mixable at any possible ratio. The dual triode 12AX7 tube delivers a warm and comforting sound with smooth high frequencies while still preserving the ability to cut through the mix. Low self-noise and high dynamic range exemplify how the LCT 940 is vintage design brought into the present.

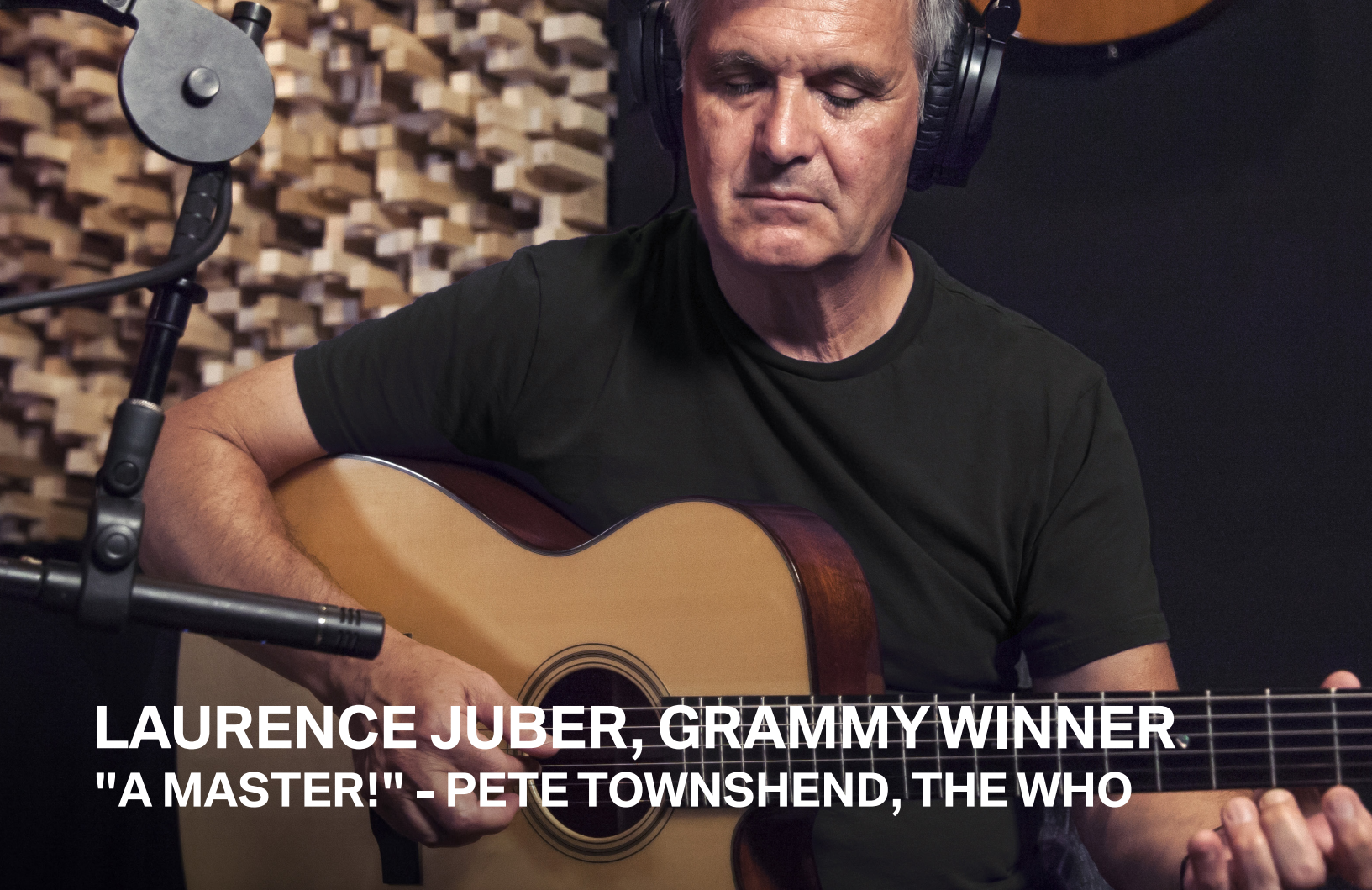

LAURENCE JUBER, GRAMMY WINNER.
"A MASTER!" - PETE TOWNSHEND, THE WHO



LCT 040 MATCH

Condenser, Small Diaphragm, Stereo Pair

Matched pair for outstandingly precise stereo recordings. Captures your acoustic instruments in fine, crisp detail, with pleasant high-end.

Included: Mic mounts, Windscreens, Mic bag

Single version available.

LCT 140 AIR

Condenser, Small Diaphragm

Instrument condenser microphone with two sound characteristics; linear frequency response or “airy” sound.

Included: Mic mount, Windscreen, Mic bag

LCT 340

Condenser, Small Diaphragm, Interchangeable Capsules

Professional multipurpose pencil microphone with excellent transient response.

Included: Mic mount, Windscreen, Mic bag

A close-up photograph of Yngwie Malmsteen performing on stage. He has long, wavy, dark hair and is looking upwards and to the right. He is wearing a dark jacket and is positioned in front of a silver microphone on a stand. The background is dark with some blue and green stage lighting. The text is overlaid in the bottom left corner.

YNGWIE MALMSTEEN, GUITAR LEGEND
"THE MTP 550 DM HAS ALL I NEED"



LIVE VOCALS

LEWITT's live microphones are built to last and to provide an outstanding user experience to everybody taking part in a live performance. All involved, from live engineers up to musicians, pay attention to different aspects of their gear.

That is why you can find a feature set that satisfies all individual needs. High gain before feedback, detailed and vibrant sound, easy handling and ruggedness. A perfect fit in every situation for an unforgettable user experience. The steadily growing numbers of artists and live engineers that are making LEWITT microphones their first choice underline that fact.





POPPY AJUDHA, SINGER SONGWRITER
CLASH X METROPOLIS LIVE SESSIONS

Photo © Tom Rowland



MTP 250 DM

Dynamic

The first-choice dynamic handheld microphone for ambitious singers. Switch version (MTP 250 DMs)

Included: Mic mount, Windscreen, Mic bag



MTP 550 DM

Dynamic

The new vocal performance standard. High gain before feedback, low handling noise, zero hassle. Switch version (MTP 550 DMs)

Included: Mic mount, Mic bag



MTP 840 DM

Dynamic, Active Mode

Dynamic handheld microphone with exceptionally clean sound and switchable gain settings.

Included: Mic mount, Mic bag



MTP 940 CM

THE HANDHELD STUDIO MICROPHONE



MTP 350 CM

Condenser

Professional wired handheld condenser microphone for highly detailed sound. Switch version (MTP 350 CMs)

Included: Mic mount, Mic bag

MTP 740 CM

Condenser, Large Diaphragm

Handheld performance microphone with a 1" studio condenser capsule, low-cut and pre-attenuation.

Included: Mic mount, Mic bag, Transport case

MTP 940 CM

Condenser, Large Diaphragm

True condenser studio technology in a handheld body with switchable polar patterns.

Included: Mic mount, Mic bag, Transport case



KENNY ARONOFF, STUDIO LEGEND
LADY GAGA, BRUNO MARS, SANTANA, ELTON JOHN, ...



DRUM SERIES

For live and studio performances alike, it is essential to have reliable equipment at hand. From snare to kick, LEWITT provides massive, punchy, authentic, and modern sound for all parts of the drum kit and percussion instruments. All LEWITT drum microphones are designed and engineered under a straightforward premise; to be like a good drummer—inspirational and reliable at the same time.





DTP 340 REX

Dynamic, Sound-shaping Modes

Dynamic kick drum microphone with switchable sound characteristics.

Included: Mic bag

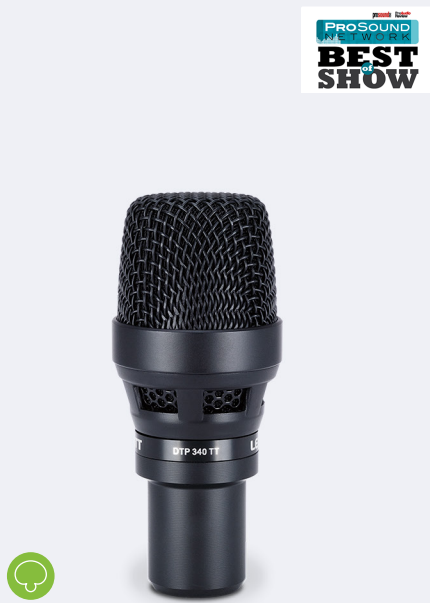

DTP 340 TT

Dynamic

Tom and percussion microphone for transient-rich and punchy sound.

Included: Mic mount for drums,
Mic mount, Mic bag



MTP 440 DM

Dynamic

Highly versatile dynamic instrument microphone.

Included: Mic mount, Mic bag



// MASSIVE SOUND FOR YOUR KICK
// DUAL ELEMENT TECHNOLOGY
// THREE SOUND-SHAPING MODES
// FOR BASS-HEAVY APPLICATIONS



DTP 640 REX

**Dynamic, Condenser,
Sound-shaping Modes**

Dual element kick drum microphone with switchable sound characteristics. Suitable for all bass-heavy applications.

Included: 5-pin audio cable, Mic bag

Details:

The DTP 640 REX features an innovative dual element design, that combines a dynamic and a condenser capsule in one housing. Switchable frequency responses make for kick drum sounds that are rich and intense or flat and neutral. The dynamic element ensures accurate reproduction of kick drum attack, while the condenser element captures the drum's low end. In order to ensure full control over the two elements, each has a dedicated output.



DTP BEAT KIT 6

1 DTP 340 REX

3 DTP 340 TT

2 LCT 140

TRANSPORT CASE

Details:

This 6-piece drum mic kit includes one DTP 340 REX and three DTP 340 TT supercardioid dynamic drum mics, two LCT 140 condenser mics, windshields, and drum- and shock mounting systems, and it comes in a convenient military-grade protective case. Be prepared for fine-tuned drum sound with extraordinary detail and impact both onstage and in the studio.



DTP BEAT KIT PRO 7

1 DTP 640 REX
3 DTP 340 TT
2 LCT 340
2 LCT 340 OC
1 MTP 440 DM
TRANSPORT CASE

Details:

The DTP Beat Kit Pro 7 is an elite full-spectrum drum mic set designed for the ever-growing number of professional drummers and sound engineers who want a high-performance all-round kit that enables them to reproduce authentic, powerful, detail-rich sound in any setting. From upscale studio projects to big live acts, the DTP Beat Kit Pro 7 provides just the kind of reliable premium gear you need for a memorable performance.

A photograph of four young men sitting on a light-colored, textured sofa in a studio setting. They are all smiling and laughing. The man on the far left is wearing a plaid shirt over a black t-shirt and black pants. The man next to him is wearing a light blue jacket over a black t-shirt and blue jeans. The man in the center is holding a black microphone and wearing a colorful floral patterned shirt and black pants. The man on the far right is wearing a brown jacket over a white t-shirt and blue jeans. A large, dark, textured tapestry hangs on the wall behind them. To the right, there is a floor lamp with a gold-colored shade and a black tripod base. The floor is covered with a white, shaggy rug. In the bottom left corner, there is white text.

**FAREWELL DEAR GHOST
AMADEUS AWARD WINNER**



BROADCAST

Great speech quality, sturdiness, and reliability.







INTERVIEWER

Dynamic

Omnidirectional interview microphone with sturdy casing and comfortable grip.

Included: Mic bag, Mic flag,
Camera connection cable

Details:

This extremely sturdy dynamic microphone features an omnidirectional polar pattern. Its capsule is fully rubber mounted. In combination with the INTERVIEWER's new coating technology all handling noise is reduced to a minimum while offering safe and comfortable grip. With the purpose-built Dust Protection Membrane and its heavily rugged, most resilient housing, the INTERVIEWER will be the perfect companion even under the roughest conditions.



pitch

mod

Teals

00:58.86

RETURN

IN

OUT

DIRECT

0 dB

-10 dB

20 dB

GAIN L R



DIGITAL

LEWITT is a microphone brand of the 21st century. As such it comes naturally that it provides a high-end digital microphone line, which delivers studio-like sound quality for modern applications. Supporting iOS, macOS, and Windows devices, these USB microphones provide crystal clear sound for bedroom recorders, professional YouTubers and Podcasters, mobile recording, and tour life. Digital recording at its best.





DGT 650

THE MOBILE RECORDING STUDIO

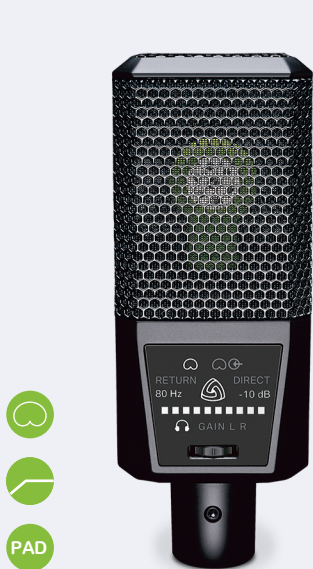

DGT 450

Condenser

Digital, feature-rich iOS // macOS // Windows USB microphone for recording and podcasts.

Included: Mic mount, DGT USB cable, DGT lightning cable, Tripod

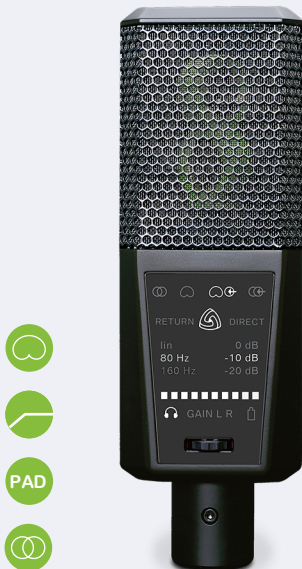

DGT 650

Condenser

Digital, iOS // macOS // Windows USB stereo microphone and audio interface in one.

Included: Shock mount, Windscreen, Breakout box, DGT USB cable, DGT lightning cable, Tripod

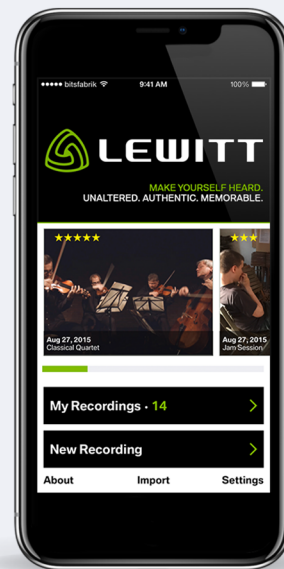

RECORDER

iOS Application

Turn your mobile into a recording device with robust cloud support and archiving functions. Free version available.



CONFERENCE

Mutual intelligibility is the basic fundament of every spoken communication. The LEWITT Conference Series provides pleasantly clear and intelligible voice reproduction for podiums, houses of worship and conference rooms of any size. State-of-the-art decoupling minimizes structure-borne noise. Handling noise is strongly reduced. All components can be exchanged effortlessly. Adapt to your preferences without compromises.





S6

Capsule

Permanently polarized condenser capsule with shotgun polar pattern. Compatible with all LEWITT goosenecks. Tailored frequency response to provide high speech intelligibility in any scenario.



S10

Capsule

This condenser capsule features a shotgun polar pattern. It provides a specifically shaped frequency response and stands for outstandingly high speech intelligibility.



LEWITT

L6200

LEWITT



GN35X2

Gooseneck

Easily adjustable with two flexible sections. Slim metal gooseneck with excellent handling-noise reduction. For S6 and S10 condenser capsule. Balanced 3-pin XLR output connector. Length: 350 mm.



GN35X

Gooseneck

Easily adjustable with one flexible section. Slim metal gooseneck with excellent handling-noise reduction. For S6 and S10 condenser capsule. Balanced 3-pin XLR output connector. Length: 350 mm.



GN15X

Gooseneck

Easily adjustable with one flexible section. Slim metal gooseneck with excellent handling-noise reduction. For S6 and S10 condenser capsule. Balanced 3-pin XLR output connector. Length: 150 mm.



B70A

Microphone Base

Sturdy microphone base with functional design for 3-pin XLR gooseneck microphones.

Balanced 3-pin XLR connectors.



B70AS

Microphone Base

Sturdy microphone base for all gooseneck microphones with 3-pin XLR connector. Mute button with LED indicator.

Balanced 3-pin XLR connectors.



3 Doors Down
Aaron Gillespie
Aaron Watson
Annihilator
Atlantic Records NY
Benjamin Wright Jr.
Bibi McGill
Bilderbuch
BONAPARTE
Bootsy Collins
Brandino
Brian Culbertson
Brian Vibberts
Bryant Siono
Charles Wakeman
Common Kings
Courtney Taylor
Derrick Wright
Elliott Randall
Family Affair Productions

Farewell Dear Ghost
Fela Davis
Greg Grunberg
Harmony Samuels
House of Riddim
Hybrid Studio's
J Boog
Jason LaRocca
Joe Wolfe
Josh Lovelace
Justin Stanley
Kaiser Franz Josef
Keith Harris
Kenny Aronoff
Kurt Hugo Schneider
Kyle Hamilton
Lil' John Roberts
Little Big Beat Studio's
Melrose Sound Studios
Nathan East

OOMPH!
Percy Bady
Postmodern Jukebox
Power Station Studio's
Puddles Pity Party
Richard Bravo
Seiler und Speer
Simon Thomas
Supa Dups
Supersonic Blues Machine
Teddy Riley
The Echo Bar Studios
The Stereotypes
Vernon Reid
Waldo Madera
Walk Off The Earth
Walter Millsap
Wayne Linsey
Yngwie Malmsteen
... and many more

ENDORSERS

PROFESSIONALS USING OUR MICROPHONES.

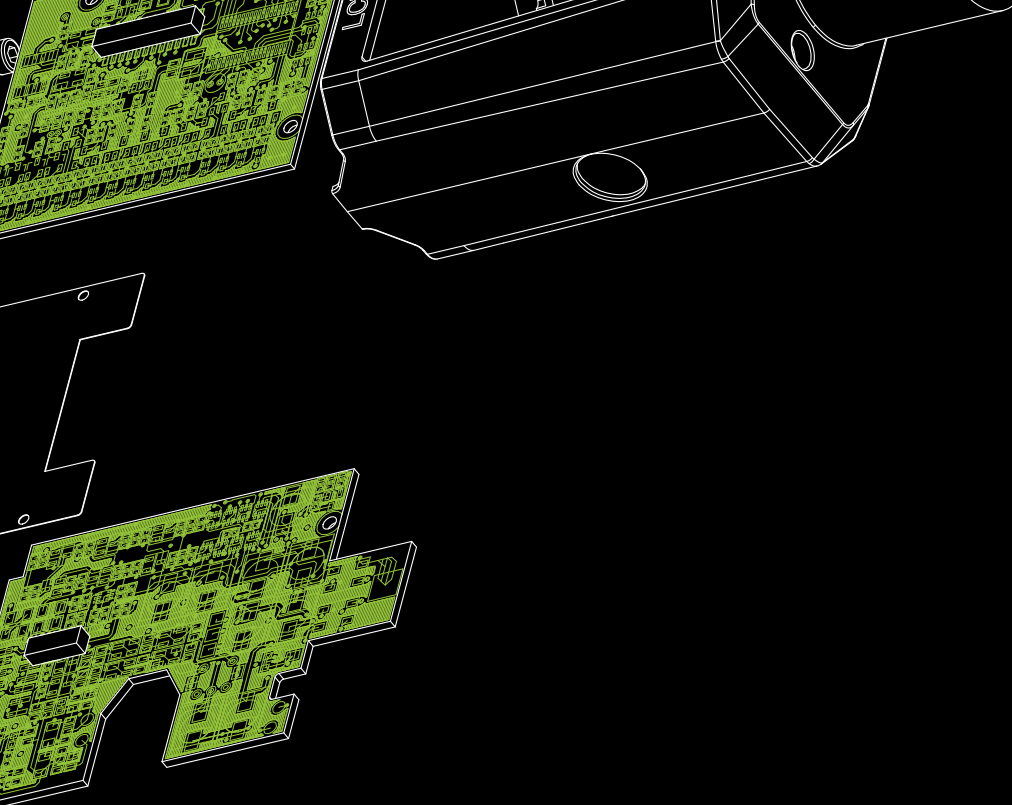

LEWITT GmbH
Schanzstraße 14
1150 Vienna, Austria

www.lewitt-audio.com
info@lewitt-audio.com